

The image shows an industrial ammonia synthesis plant. Two workers in blue overalls and white hard hats are walking through a large, complex structure of pipes and metal frameworks. They are looking at a set of papers held by one of the workers. The background features large windows and a staircase. A blue graphic overlay is on the left side of the image.

High efficient Ammonia Synthesis Systems

John Bøgild Hansen
Haldor Topsøe A/S

Haldor Topsoe

In brief

- Established in 1940 by Dr. Haldor Topsøe.
- Market leader in heterogeneous catalysis and surface science for over 70 years.
- 2,300 employees in 11 countries across five continents.
- Headquarters in Lyngby, Denmark.
- Production in Frederikssund, Denmark, and Houston, USA.
- Spend more than 10% of revenue on R&D.



2018

Revenue AUD 1,220 million

EBIT AUD 154 million

EBIT margin of 13%

Net profit of AUD 107 million

Topsoe Ammonia Catalyst Charges and Ammonia Plants

Topsoe is the market leader

248 current catalyst references worldwide

Number of plants: 60

Accumulated capacity, MTPD: 99,505



Topsoe classical ammonia process

Very energy efficient but emits 1.6 MT CO₂

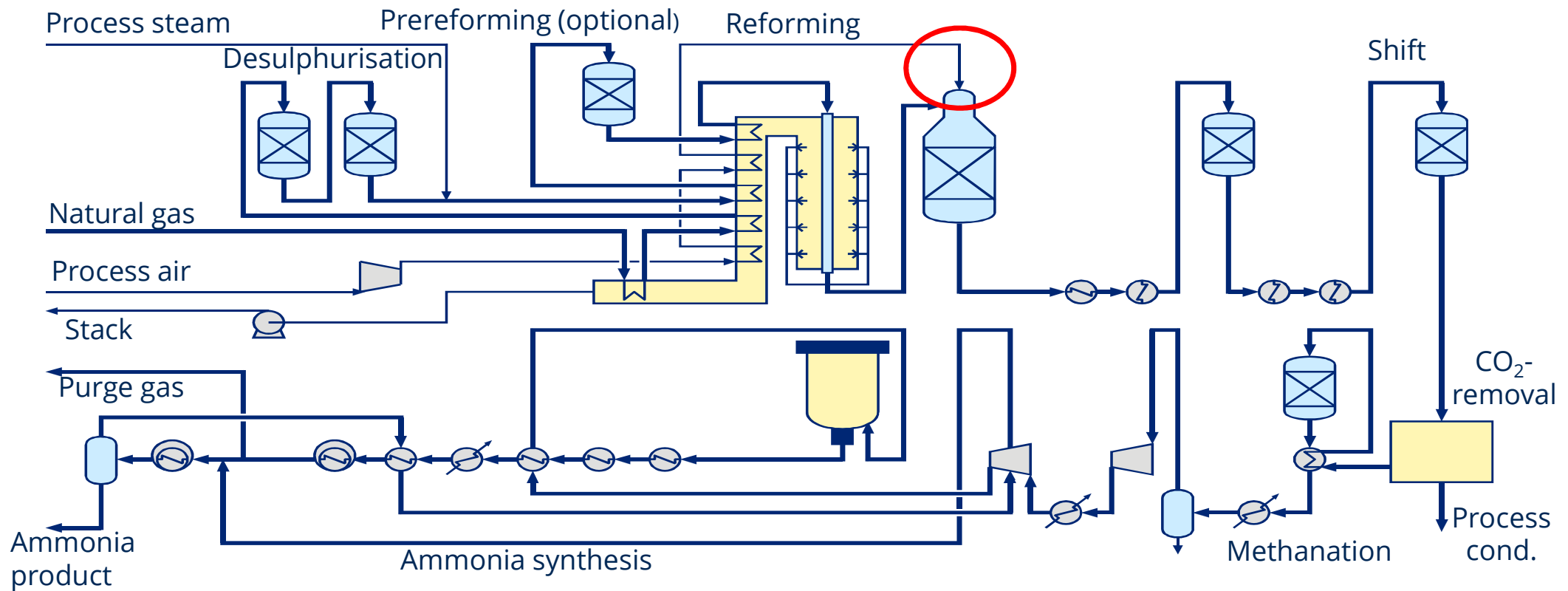

Power-to-X – electrification of ammonia production

- Ammonia production accounts for approximately **1% of the global total energy use**
- Ammonia production accounts for 17 % of all chemical and petrochemicals energy use
- **Half the world food production** depends on synthetic ammonia
- 180 mio tons produced annually
- If produced at 7.2 MWh/MT with SOEC => equivalent to 325 GW @ 4000 h/yr wind or 41000 world class 8 MW turbines
- Ammonia LHV 18.6 GJ/MT=5.16 MWh/MT
- Ammonia excellent carbon free energy carrier of the future

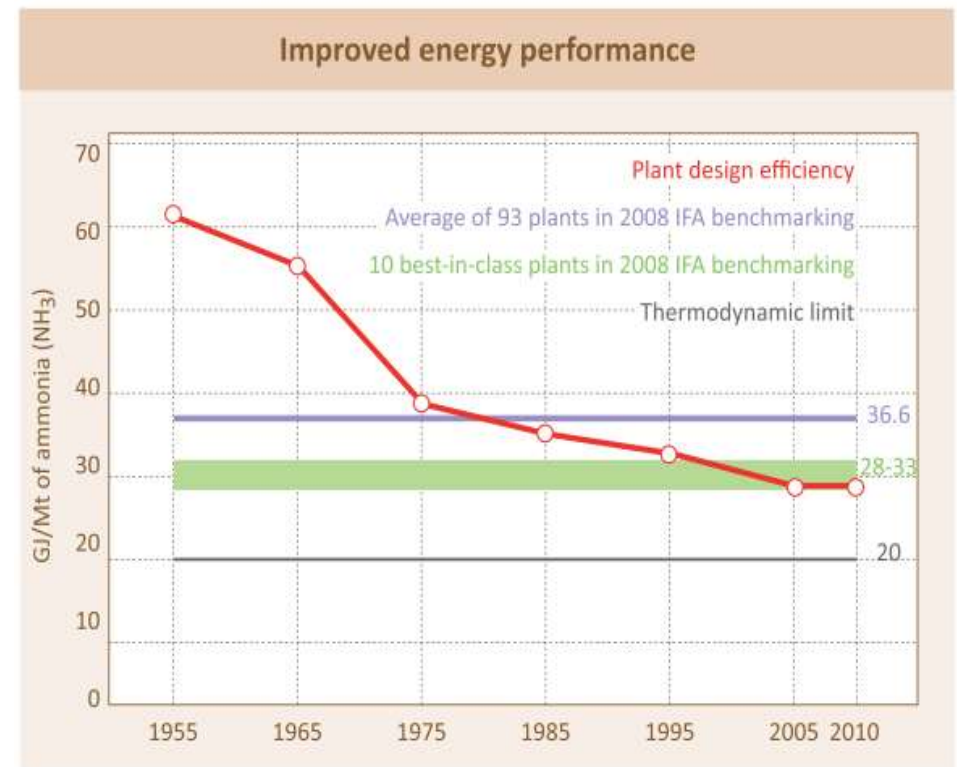

The hybrid plant solution

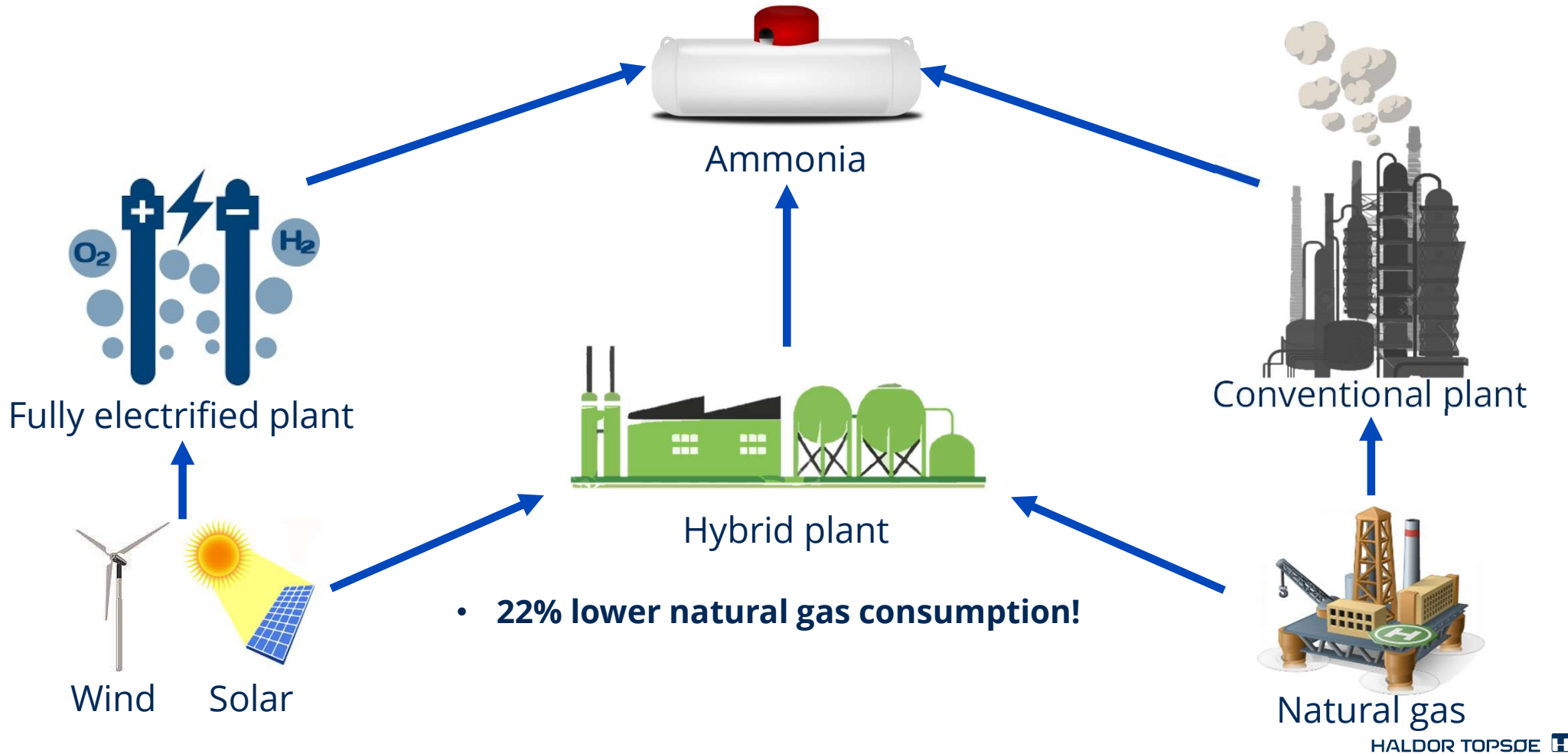

Power-to-X – electrification of ammonia production

Haldor Topsoe's future vision

- Electrolysis offers potential to **de-couple chemical synthesis from CO₂ emissions**
- SOEC is attractive due to its ability to separate oxygen from air and incorporate waste heat to save power resulting in **lower investment** and **higher efficiencies**.

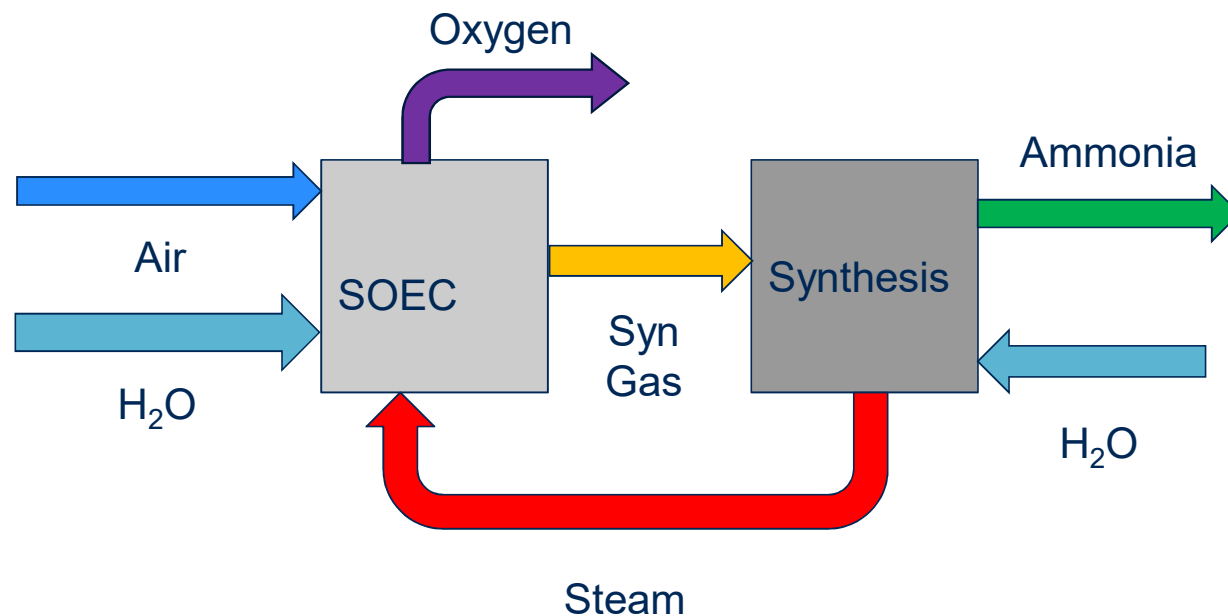

New EUDP project : 1.5 kW SOFC and 50 kW SOEC producing 20 Nm³/h NH₃ synthesis gas



Participants:

Haldor Topsøe A/S
Aarhus University
DTU
Energinet.dk
Vestas
Ørsted
Equinor

Coordinator:

HALDOR TOPSØE 
CATALYSING YOUR BUSINESS

Duration:

January 2019

April 2022

Project sum:

3.5 mio €

Location:

Foulum &

DTU



SOEC in Biogas upgrading Demonstration Unit

Operating in Foulum, Denmark



- 50 kW SOEC unit for steam electrolysis
- Catalytic methanation
- The CO₂ in the biogas is upgraded to pure methane with pipeline quality.
- High Exergy Efficiency of 80%

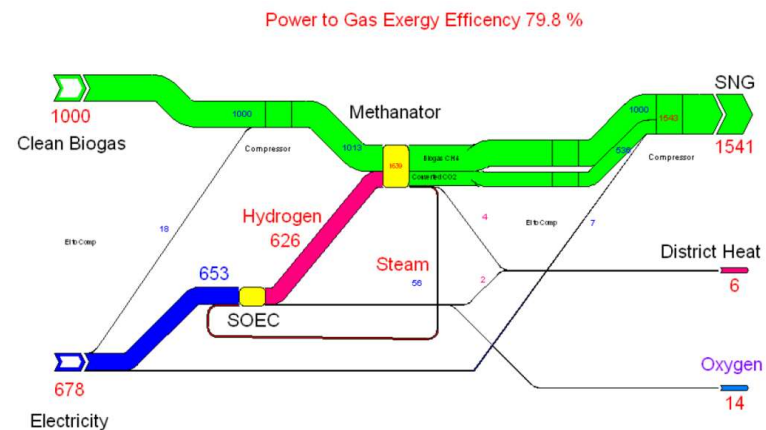

SOC Fuel Cell and Electrolyser

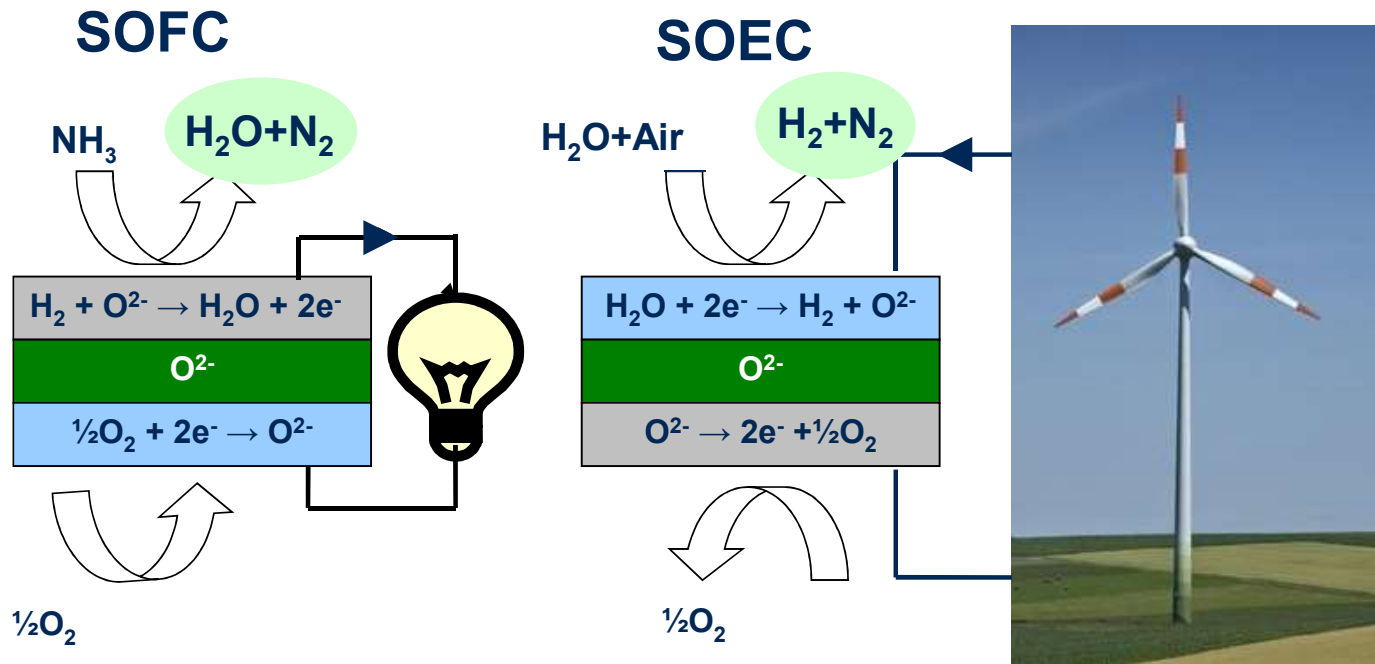

SOC also performs as

- Oxygen separation membrane
- Ammonia Cracker
- Heat exchanger

SOEC more efficient than present Electrolysers

Internal waste heat used to split water

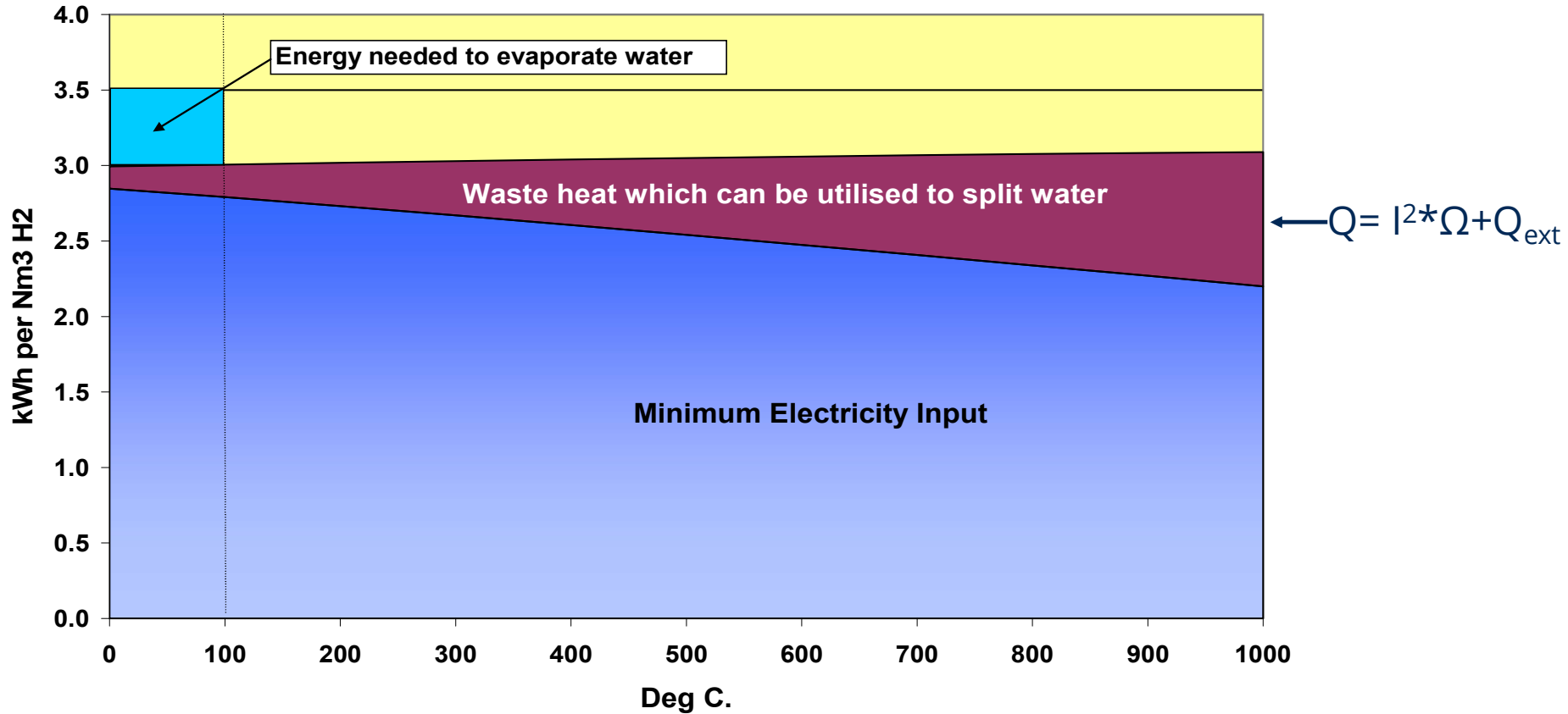

Ammonia production with SOEC and Air Separation Unit

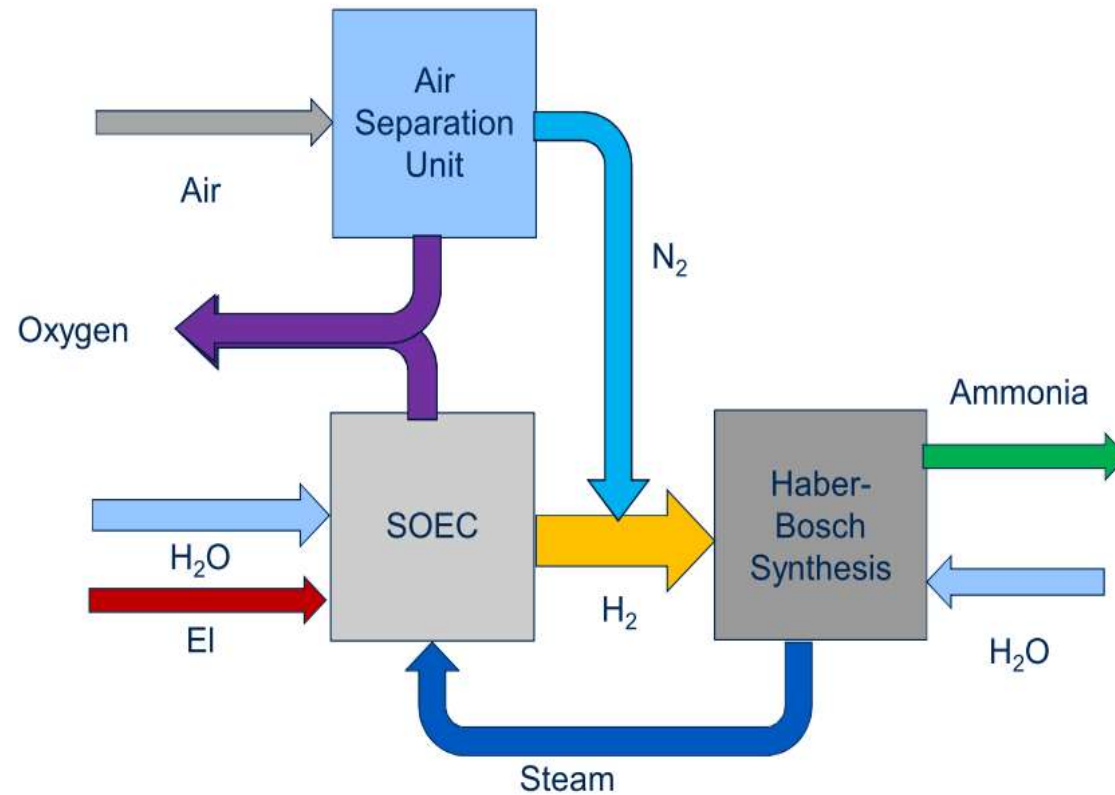

SOEC based ammonia plant with air separation unit

e.g. hydrogen production only

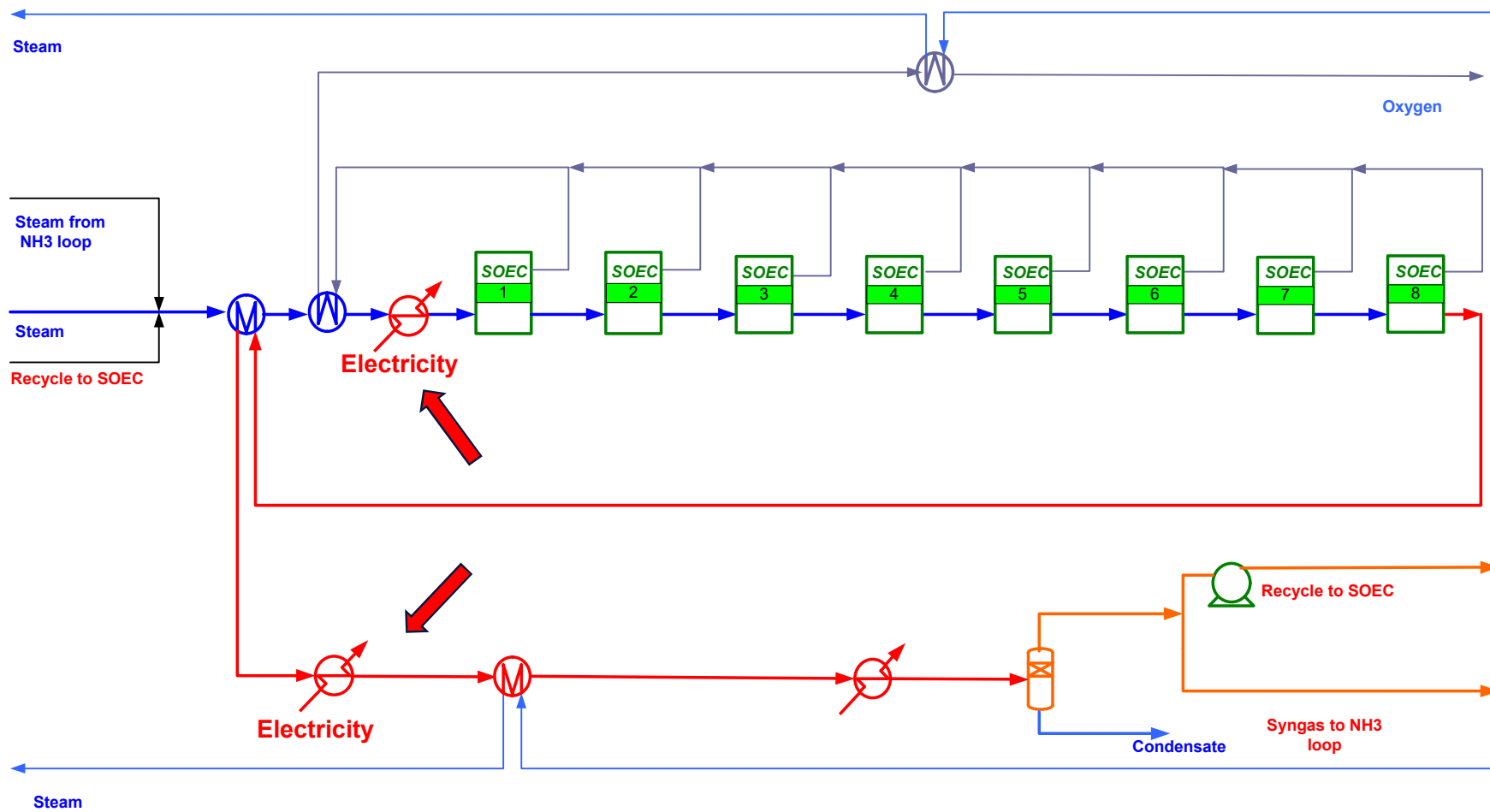

SOEC without separate air separation unit

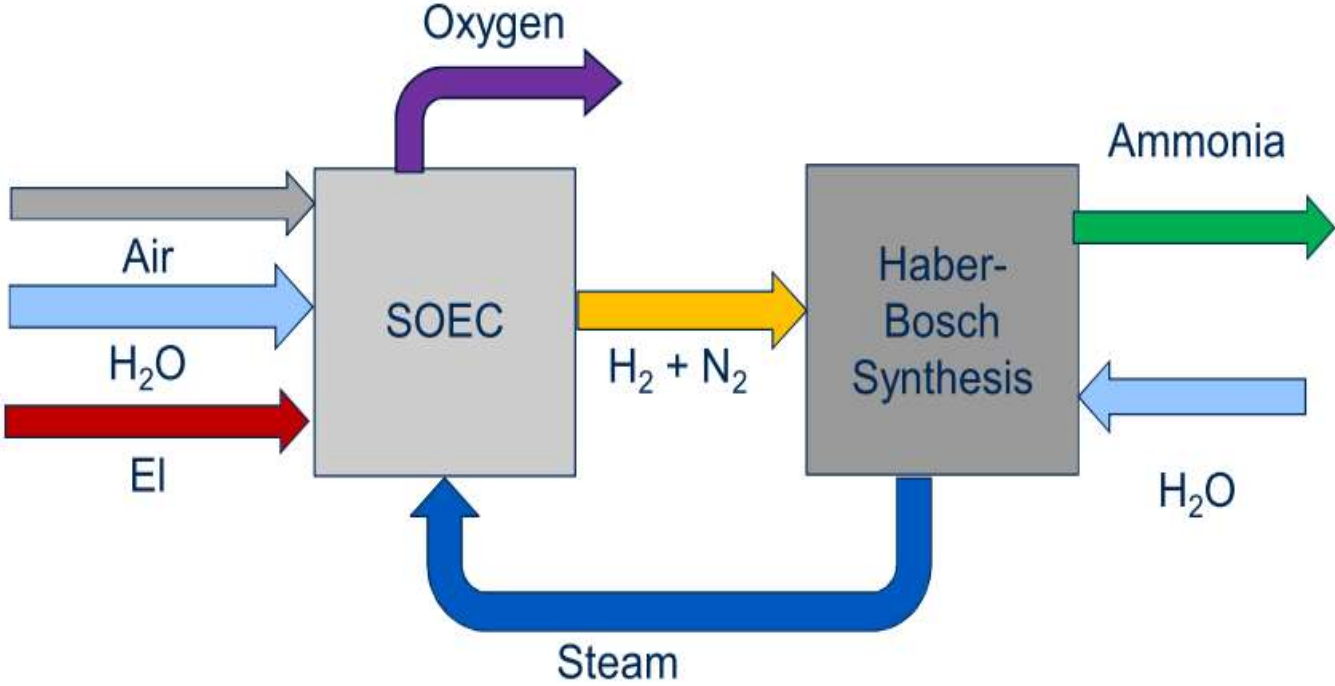

Ammonia syngas by SOEC

Approximate mass balances with Steam conversion 80 %

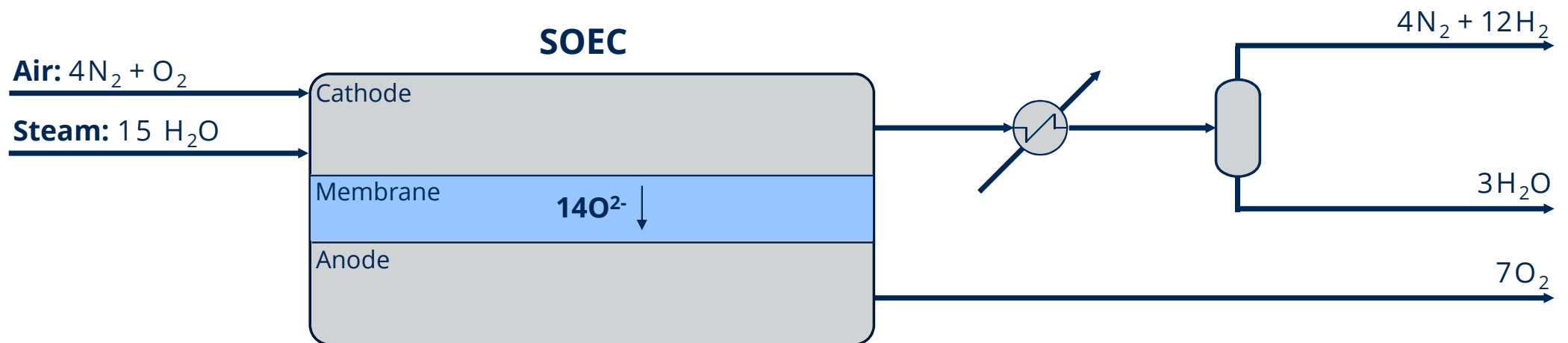

Ammonia Synthesis Gas Generation by SOEC – patent pending

Efficiency = 77 % on exergy basis – 71 % on LHV basis

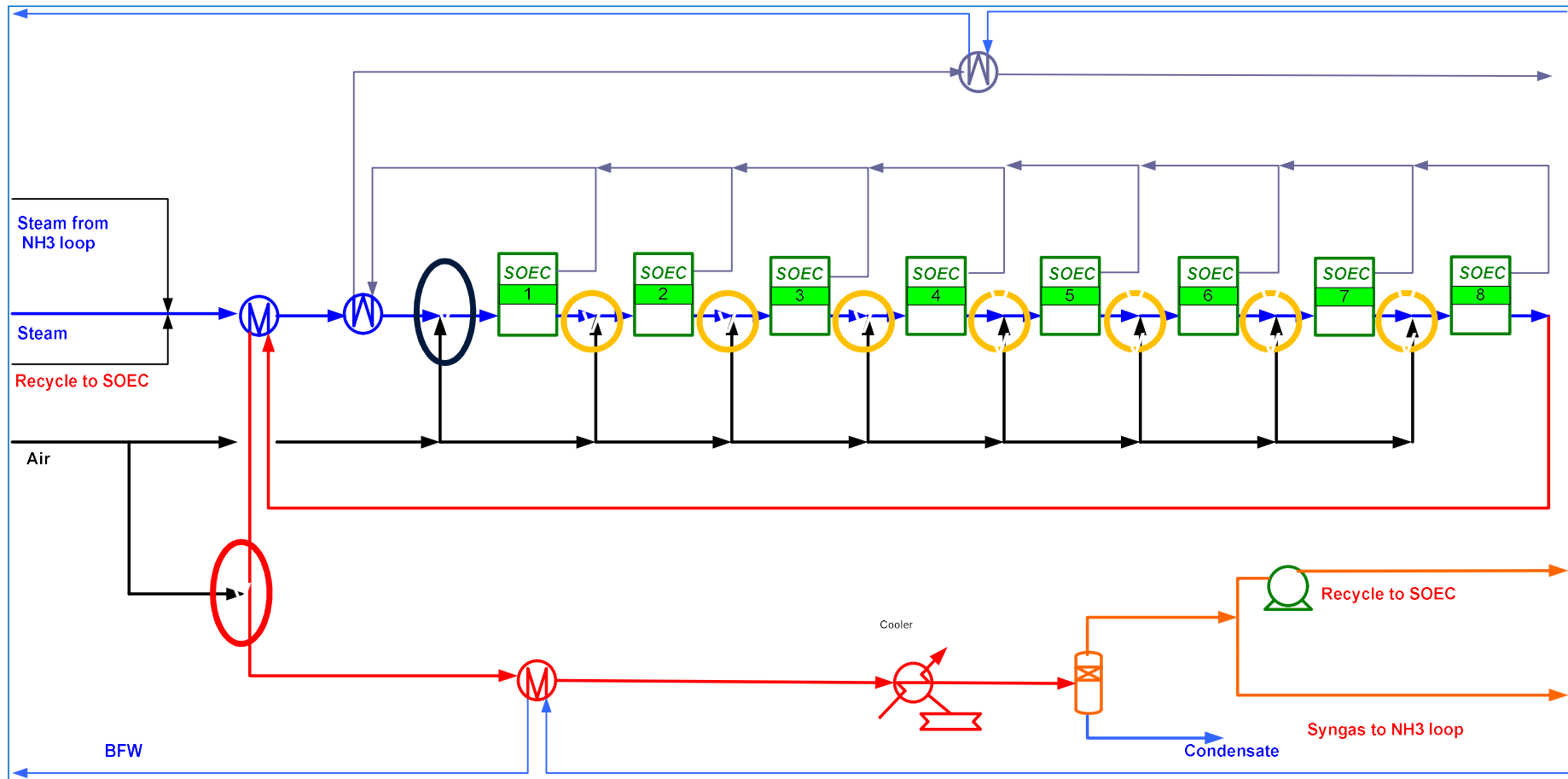

Breakdown of power consumption in kWh per MT ammonia

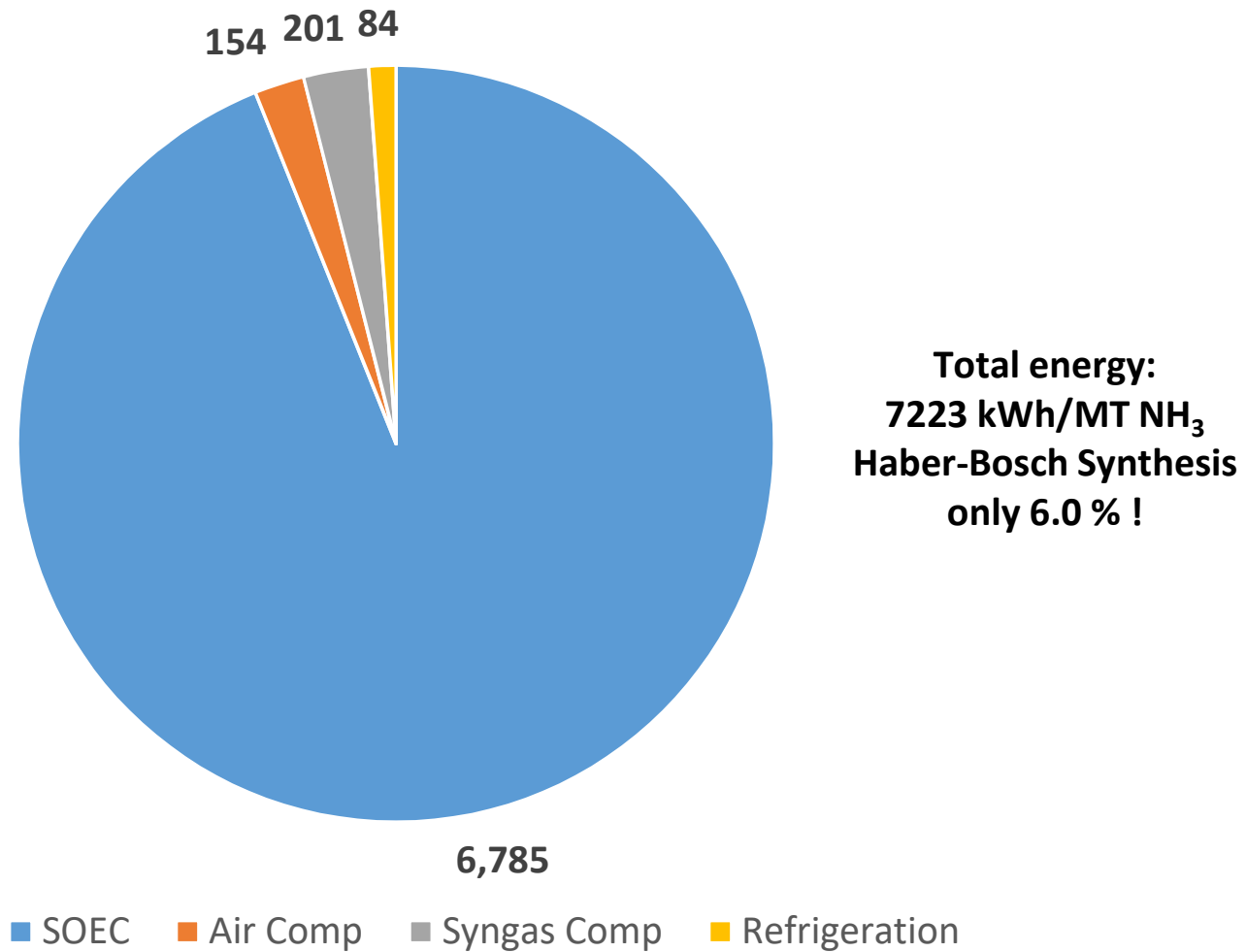

Green Ammonia Road map

Alkaline electrolysis

SOEC electrolysis

SOEC electrolysis – Development & maturing & Demos

Conventional and SyncCOR™ Processes

Hybrid revamp solution

Hybrid grassroots solution

500 – 1000 kg/d SOEC+HB Demo

Commercialize Electrolyzer+HB

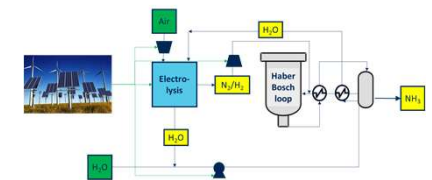
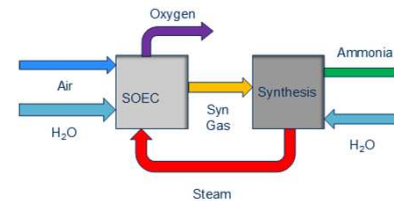
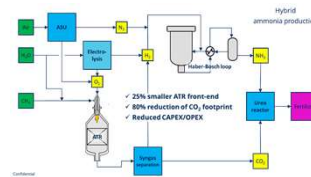
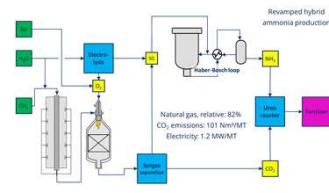
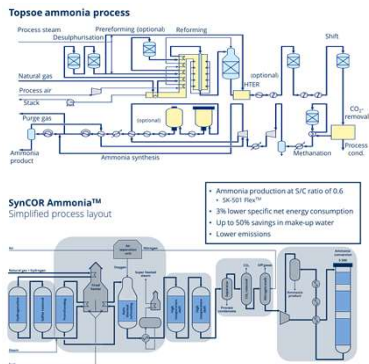

Ammonia Track

2018

2020

2022

2025

2030

Direct use of Ammonia for SOFC

Electrical efficiency > 60 % LHV

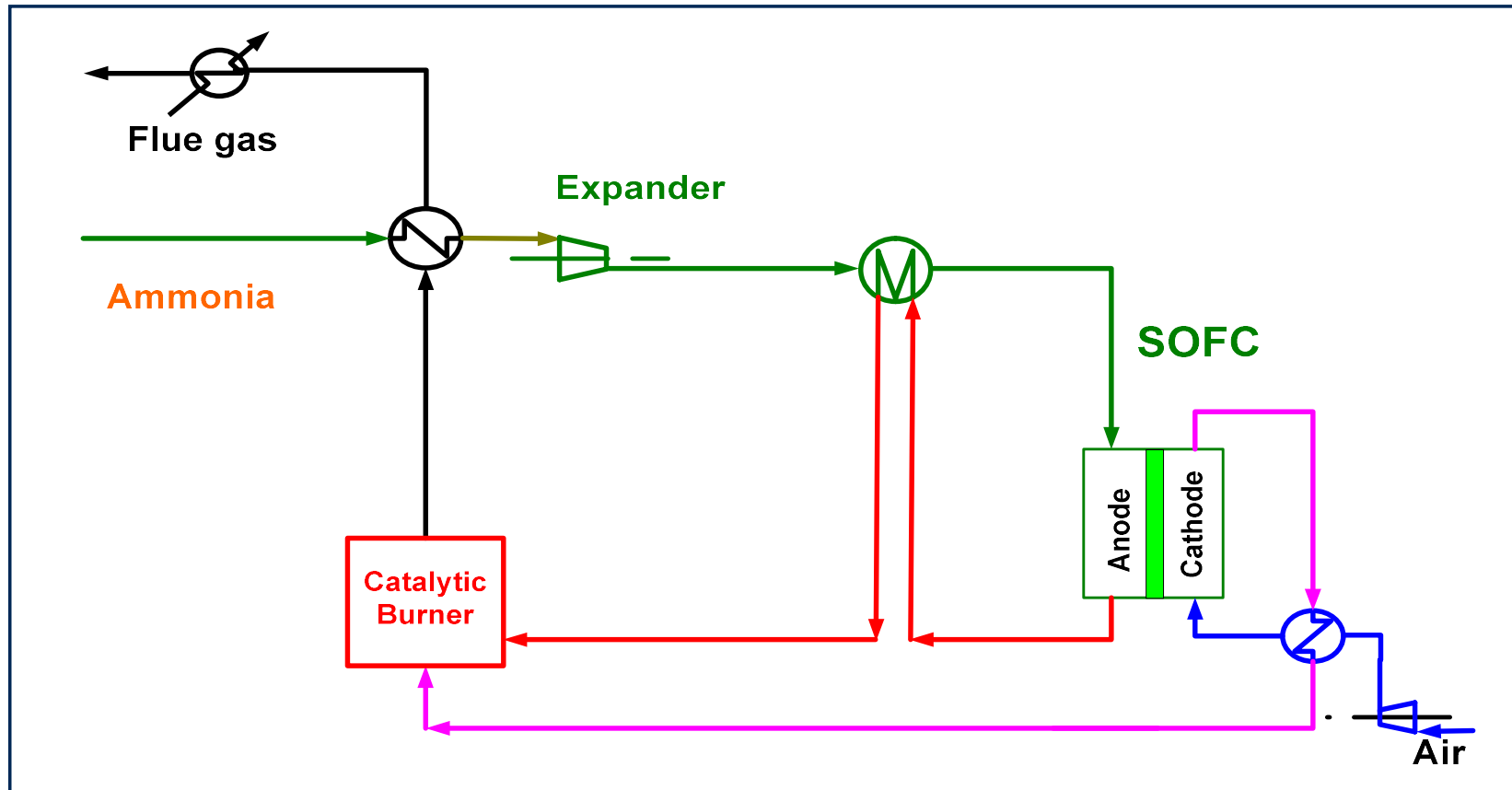

Coupling of NH₃ Cracking and Electrochemical Reactions



Direct use of ammonia in SOFC

Experimental results from DTU Energy

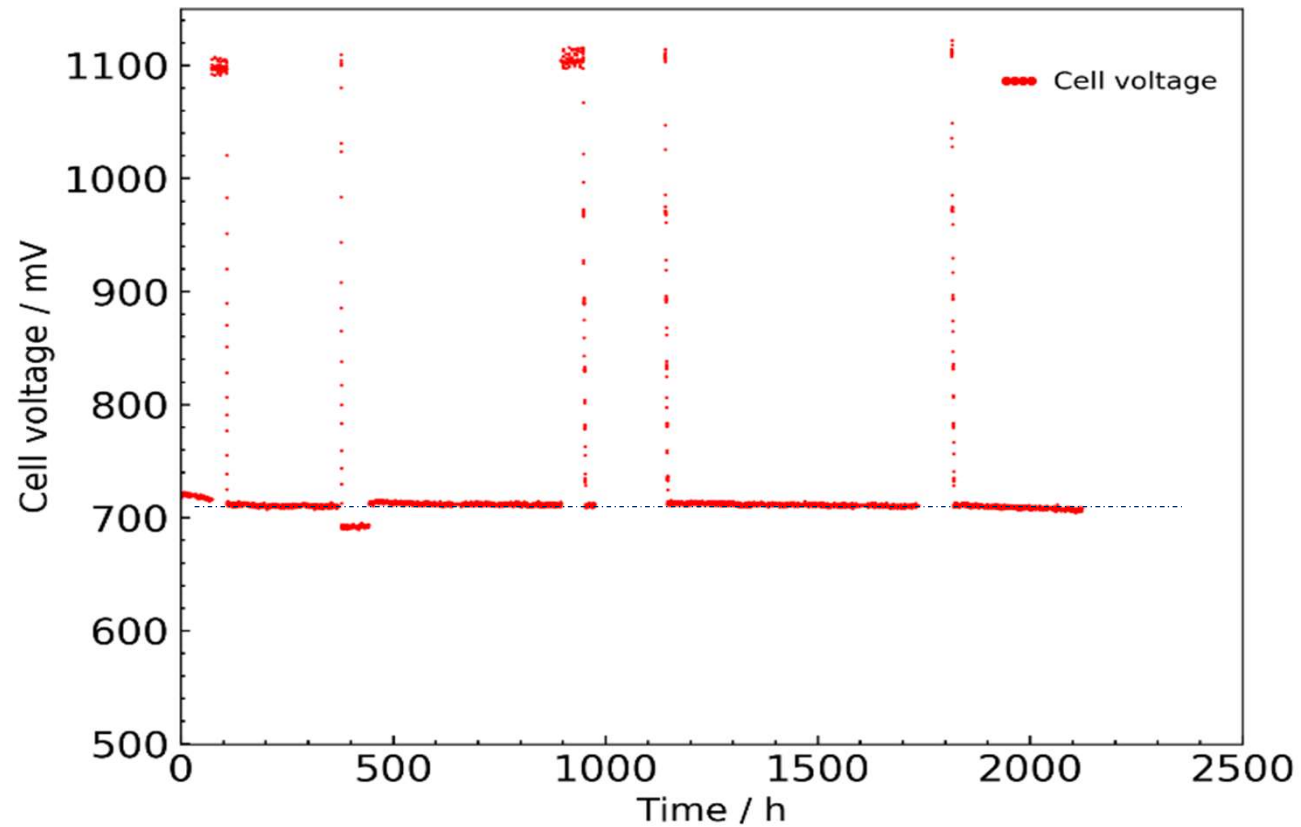

Conclusions

- New Solid Oxide Electrolysis based synthesis gas process
 - Synergy with HB using steam from synthesis reaction
 - Eliminates air separation unit due SOC “built in” oxygen separation
 - Utilize heat of air combustion to split steam
 - Have very high efficiency
- Ammonia is the perfect fuel for Solid Oxide Fuel Cells
 - No fuel processing
 - No carbon problems => no need for steam addition => high Nernst potential inlet
 - Cooling by ammonia cracking



Making optimal
performance
possible